

DIAGRAMA PARA DETERMINACION DE LIMITES DE FABRICACION (PRESION DE VIENTO)

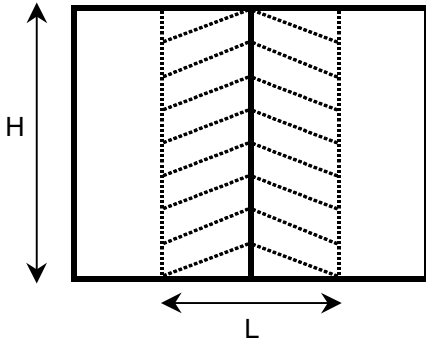

* Flecha máxima $H/300$

| CLASIFICACION | Presión (Pa) |
|---------------|--------------|
| C1 | 400 |
| C2 | 800 |
| C3 | 1200 |
| C4 | 1600 |
| C5 | 2000 |

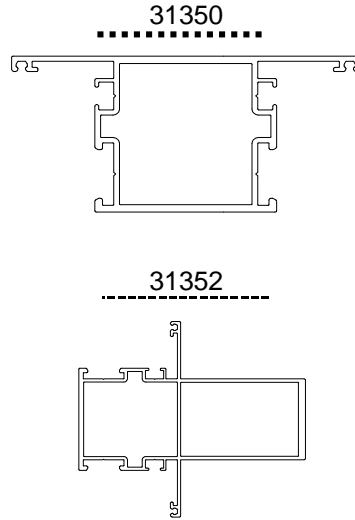
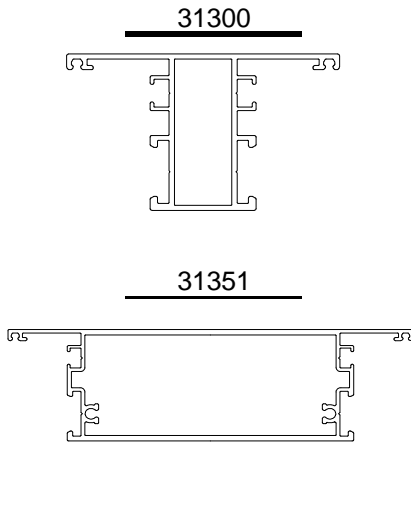

C1 Presión 400 Pa = 92 Km/h veloc. viento



DIAGRAMA PARA DETERMINACION DE LIMITES DE FABRICACION (PRESION DE VIENTO)

C2 Presión 800 Pa = 131 Km/h veloc. viento



C3 Presión 1200 Pa = 160 Km/h veloc. viento

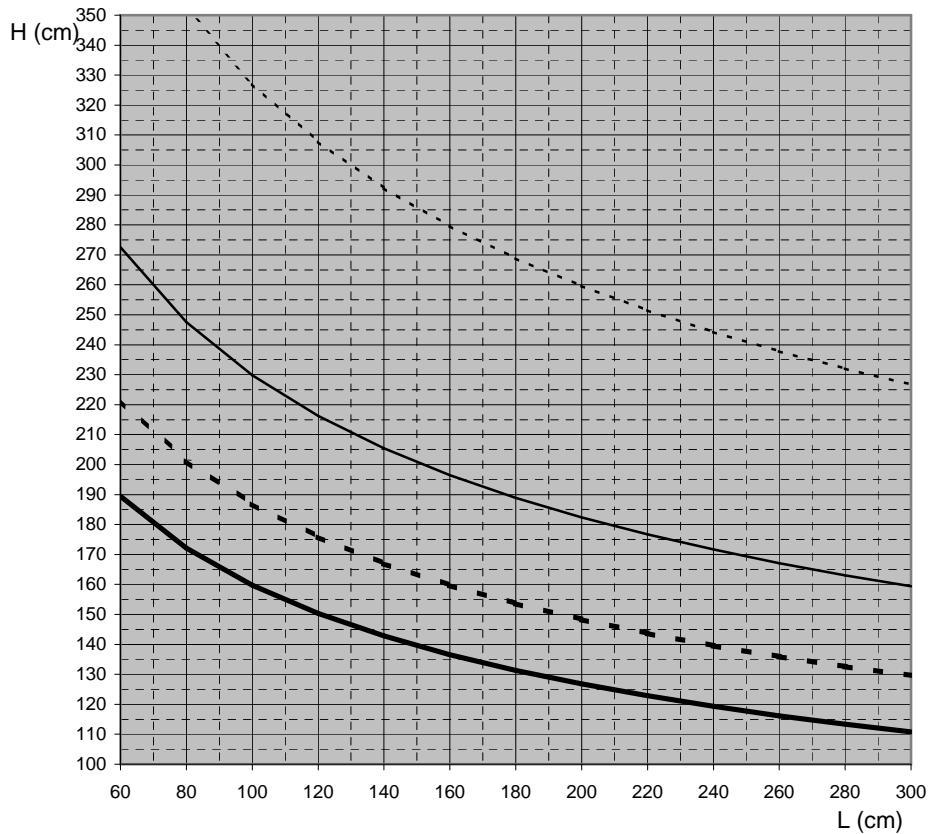
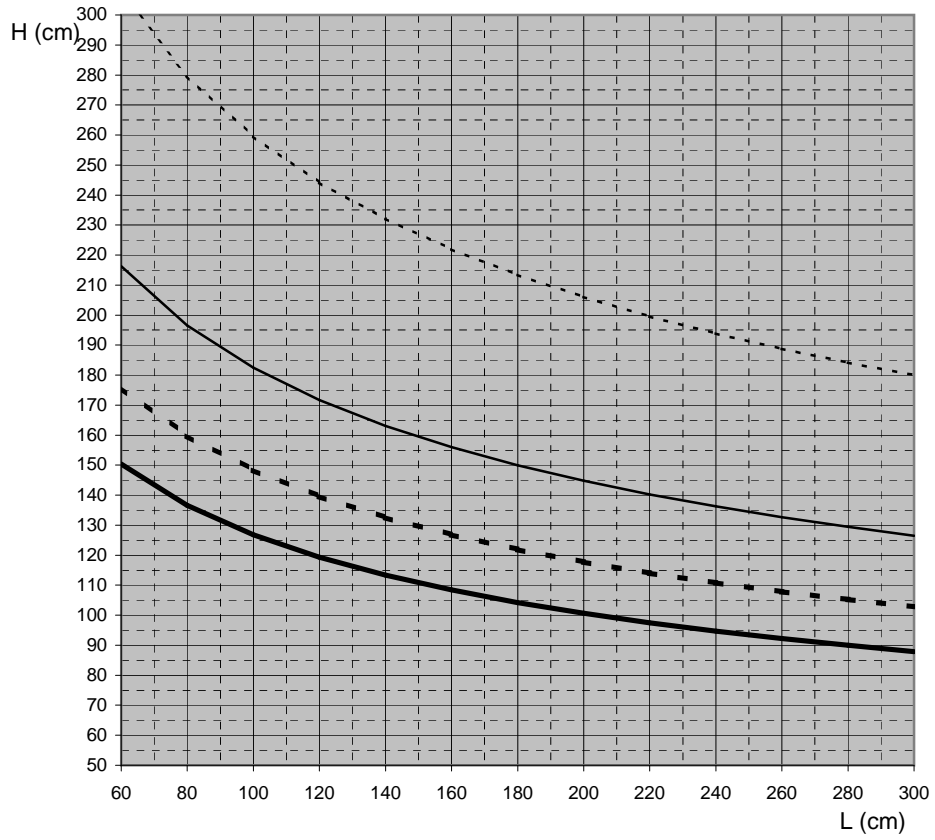

DIAGRAMA PARA DETERMINACION DE LIMITES DE FABRICACION (PRESION DE VIENTO)

C4 Presión 1600 Pa = 185 Km/h veloc. viento



C5 Presión 2000 Pa = 207 Km/h veloc. viento

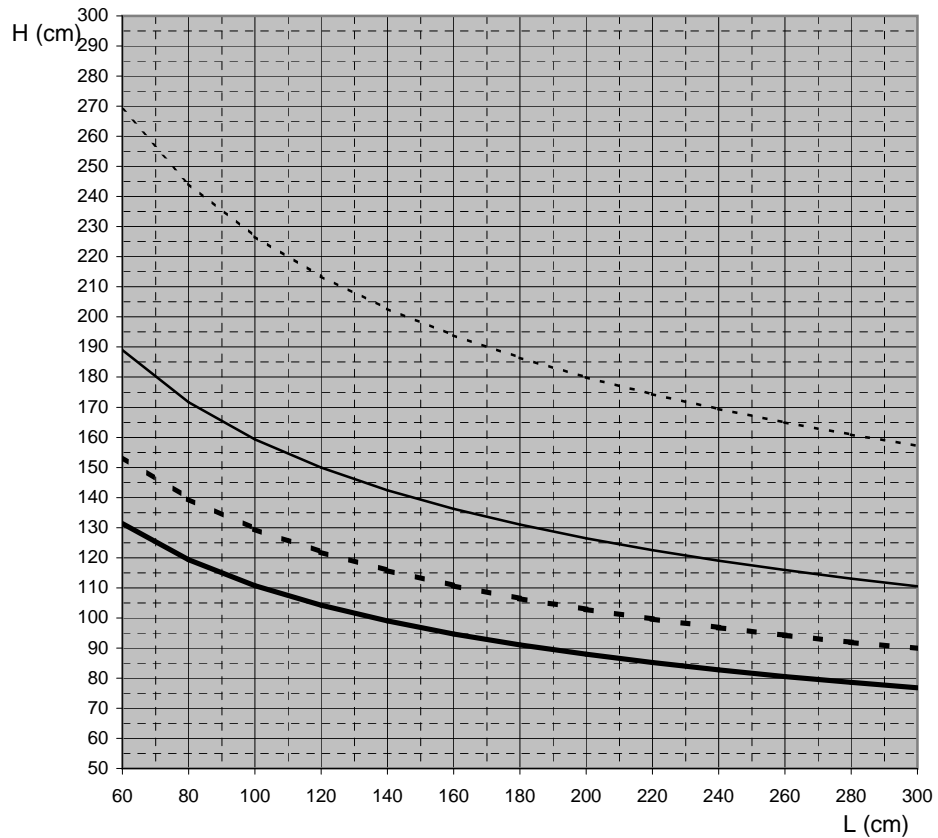
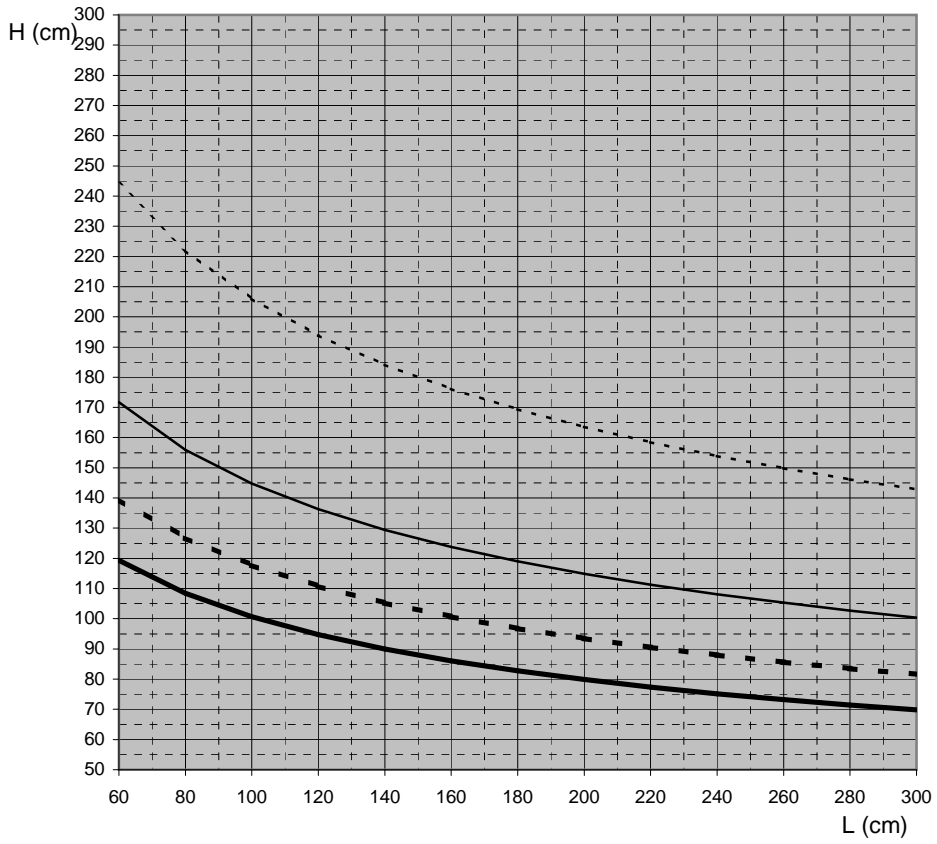